

THOUGHT EXPERIMENTS, EINSTEIN, AND PHYSICS EDUCATION

by Art Stinner and Don Metz

More than two decades ago, Clifford Swartz wrote an editorial in *The Physics Teacher* entitled: "On the teaching of Newtonian Physics to Aristotelian minds in the days of quantum operators" [1]. Swartz challenged physics teachers to keep abreast of contemporary physics for their own development and then urged them to introduce physics using ideas that allowed students to connect to modern physics more easily. He was convinced that the transition from the classical ideas of Newton to those of Einstein in the university classroom was too abrupt, and students, he suspected, found these new concepts "unnatural".

The main concepts of quantum theory and relativity are generally only hinted at in senior high school physics and in first year university. It is certain that after the recent centenary of the *annus mirabilis* of Einstein's revolutionary papers in 2005, we will again see a call for an earlier introduction of modern physics into the secondary physics curriculum, especially of the ideas of Einstein. In this paper, we are advocating the use of thought experiments (TEs) as a means to introduce modern topics, in particular Einstein's work on relativity. We begin by addressing the main historical antecedents of his work, namely two TEs by Galileo, and two by Newton that were foundational for his special theory of relativity (STR). We will then illustrate the use of TEs that led to the conclusions reached in his article of 1905, in what is now called the special theory of relativity (STR). We will conclude with the TE that touches on the foundation of the general theory of relativity (GTR).

In his miracle year of 1905, Einstein's three revolutionary papers on Brownian motion, the quantum nature of radiation, and relativity, were not immediately accepted, and only sporadically acknowledged. However, the ideas developed in these papers were all trail-blazing, at least as seen in retrospect. In the first paper, Einstein showed that it is possible to determine Avogadro's number by observing the paths of particles of about 1 micron size in a microscope, thus providing strong evidence for the existence of atoms. In the second paper, he showed that E-M radiation can be thought of in terms of "particles" that interact with matter to produce experimentally determinable evidence, such as the photoelectric effect. The third paper argued that two axioms, or what Einstein called postulates, that is, the relativity principle and the constancy of the speed of light, are sufficient to deduce the Lorentz transformation equations.

It is certain that, after the recent centenary of the *annus mirabilis* of Einstein's revolutionary papers in 2005, we will again see a call for an earlier introduction of modern physics into the secondary physics curriculum, especially the ideas of Einstein.

It must be kept in mind that the theory of relativity is actually connected to two theories: the special theory (STR) and the general theory (GTR). The STR was developed by Einstein between about 1895 and 1905 and the GTR between 1907 and 1915. We, of course, must acknowledge the work of Lorentz, Poincaré and others in developing many of the components of the STR. In fact, one of the reasons Einstein's paper of 1905 was largely ignored (except for Planck and a few others) was that the main findings recorded in the paper, the Lorentz transformations, the length contraction, the relativistic velocity addition, and even the idea that $E = mc^2$, published as an addendum a little later, were anticipated by Larmor, Lorentz and Poincaré. Specifically, it was well known that a direct consequence of Lorentz's conception of the stationary ether is that the velocity of light with respect to the ether was constant, independent of the motion of the source of light. Lorentz transformations were known to be those transformations which leave Maxwell's equations invariant [2].

THOUGHT EXPERIMENTS

TEs have a long history and a natural connection to the development of physical concepts. They can be traced back to Zeno's paradoxes of motion and Aristotle's program of explaining phenomena guided only by naked eye observation and rational thought. Galileo championed TEs to show that motion, as observed on a ship moving with a constant speed in a straight line, cannot be distinguished from motion observed at rest. He also presented TEs to argue that the motion of heavy objects in free fall are identical and presented TEs to clarify the concepts of speed and acceleration. Newton described two TEs in his *Principia* in order to demonstrate his notion of absolute space. Later, Mach developed the idea of the "Gedankenexperiment" (German for TE) to include them in physics education, and Einstein raised TEs to a high level of abstraction to clarify his ideas in both theories of relativity and in probing the foundations of quantum theory [3].

TEs can also take on different roles in our understanding and development of physics. Some TEs shake the very founda-

**A. Stinner <stinner@cc.umanitoba.ca>, Professor,
Faculty of Education, University of Manitoba;
D. Metz <d.metz@uwinnipeg.ca>, Associate Professor,
Faculty of Education, University of Winnipeg.**



tions of a theory and promote debate, often over extended periods of time. Examples of this kind of TEs are Galileo's argument to refute Aristotle's claim that the rate of descent of an object in free fall is independent of weight, Newton's bucket experiment combined with his "two globes in the void" TE, to argue for absolute space, and Einstein's "elevator in space" TE to show that gravitation and acceleration are equivalent.

TEs can also be used to clarify familiar concepts or situations or to extend the concepts to new and diverse situations. TEs of this type often respond to the question: "what if...". For example, consider the time it takes for an object to fall through a 'tunnel' that goes through the center of the earth, and then comes back again to the original point. Compare this time to the period of a pendulum that has a length of the radius of the earth and the period of a satellite in a circular orbit just above the surface of the earth (taken as a perfectly smooth sphere without an atmosphere). Many other "what if" types of TE will be both interesting and informative for your students to debate. "What if the Olympics were held on the moon?" describes such a case.

On the following pages you will find a set of TEs that we believe address the fundamental concepts leading to Einstein's theory of relativity. Most of these TEs are readily available from diverse sources. However, as far as we know, there are very few publications that discuss explicitly from a historical perspective the connections between TEs and the placing of the STR and the GTR into the secondary physics curriculum. We believe that physics teachers and students could find our story-line presentation of TEs a provoking and exciting alternative to the standard physics fare. To enrich the presentation we have tried to embed relevant historical comments to show the evolution of ideas and concepts that led to Einstein's work. This summary should therefore assist the physics teacher in preparing her lessons for the presentation of the TEs as well as becoming better acquainted with the history connected with them. Finally, we should remember that the process of argumentation given in the TE is as important, or more important than the final conclusion.

GALILEO'S THOUGHT EXPERIMENTS

Galileo argued that if a sailor dropped a canon ball from the mast of a ship that was smoothly moving with a constant velocity, the cannon ball would fall directly below him. Whatever the sailor would do, assuming a smooth constant velocity in a straight line, he would not be able to tell that the ship was in motion if he confined his attention to the ship (Fig. 1a). Using modern terminology, Galileo thus claimed that *there is no distinction between constant motion and rest* (Fig. 1b). All of us have experienced this when travelling in a train on a level track moving with a constant speed.

We must remember, however, that Galileo's extended idea of inertia was based on another TE, namely the unimpeded circumnavigation of an object around the world. For Newton, on the other hand, inertia could be described by the motion of an object in deep space with no forces acting on it. So we can say that the Galilean-Newtonian principle states that

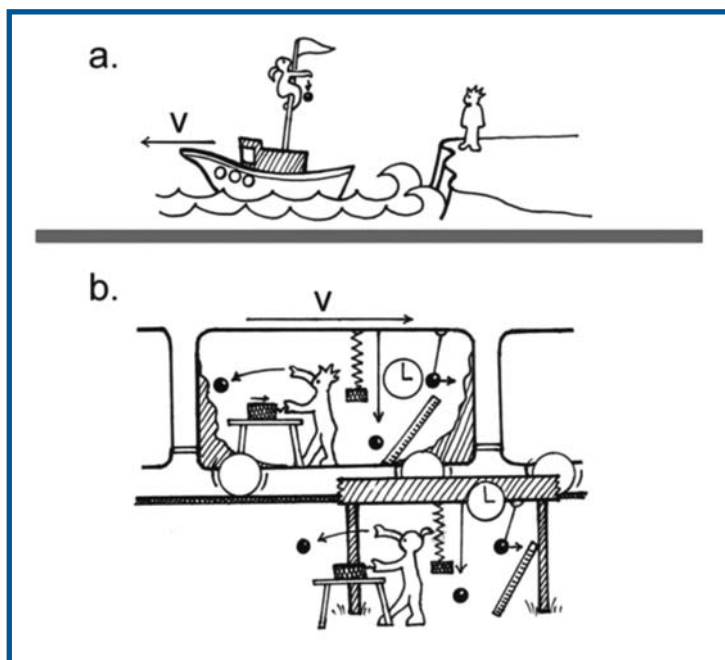

Fig. 1 (a) Galileo's ship - The sailor cannot tell that the ship is moving; (b) Galilean invariance - There is no distinction between constant motion and rest

there is no preferred frame of reference. All inertial frames are equivalent, a principle that we will find Einstein using as one of his two axioms for his special theory of relativity. We should remember, however, that in 1905 there existed no evidence against the general validity of Galilean invariance in pure mechanics^[2]. The transformation equations we use in classical physics, that students learn in their first year in high school are:

$$\begin{aligned}x' &= x - vt; \\y' &= y, \\z' &= z \\t' &= t, \text{ and} \\v &= v_1 + v_2 \text{ (velocity addition)}\end{aligned}$$

These were considered valid for all motion.

Galileo's most famous TE is the one that shows that all objects, regardless of their weight, must fall at the same rate (Fig. 2). He argued that, according Aristotle, heavier bodies fall faster than light ones ($H > L$). But what would happen if a heavy cannon ball were attached to a light musket ball? Reasoning in the manner of Aristotle leads to an absurd conclusion. First, the light ball will slow down the heavy ball

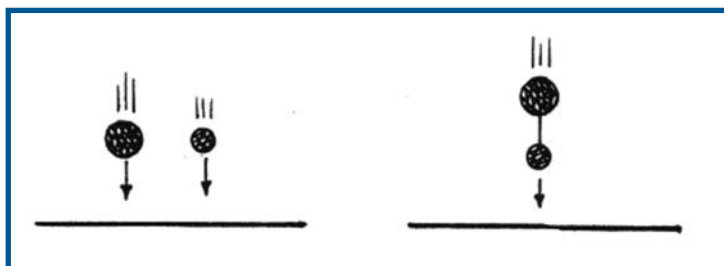

Fig 2 Galileo's falling weights TE - all objects fall at the same rate

(acting as a kind of drag), so the speed of the combined system would be slower than the speed of the heavy ball falling alone $\{(H > (H+L))\}$. But the combined system is heavier than the heavy ball alone, so it should fall faster $\{(H + L) > H\}$. But that is absurd, for how can the heavy ball be both faster and slower than even the combined system? Thus Galileo refutes Aristotle's theory of free fall [4].

NEWTON AND THE IDEA OF ABSOLUTE SPACE AND TIME

Newton's laws of motion are valid only in non-accelerating or inertial frames of reference. Newton spent a great deal of effort trying to explain this privileged status of inertial frames and postulated the existence of absolute space and time. He thought that inertial forces provided a clear indication of absolute motion. To illustrate how absolute motion could be determined he presented two thought experiments, his famous bucket experiment and the rotation of two globes in an immense void experiment. He introduced the bucket experiment as follows:

If a bucket is hanging from a very long cord and is continually turned around until the cord becomes twisted tight, and if the bucket is thereupon filled with water and is at rest along with the water and then, by some sudden force, is made to turn around in the opposite direction and, as the cord unwinds, perseveres for a while in this motion. [5] (pp 412-413).

Newton continues to describe four stages of the bucket experiment. Initially, the bucket is filled with water, the cord has not been released, and the surface of the water is level (Fig. 3.1). In the second stage the cord begins to unwind, there is a relative motion between the water and the bucket, and the water is observed to be level (Fig. 3.2). Next, the water catches up with the sides of the bucket and there is no relative motion between the water and the bucket, and the water is observed to be concave (Fig. 3.3). Finally, the bucket stops, the water is spinning relative to the bucket and the water is observed to be concave (Fig. 3.4).

At stage 2 and at stage 4, the bucket and the water are in motion relative to each other. However, in the first case the water has a level surface and in the second case the water has a concave surface. It appeared that the shape of the surface of the water was not dependent on the relative motion of the water and the sides of the bucket. Newton concluded that it was the spin of the water with respect to absolute space that

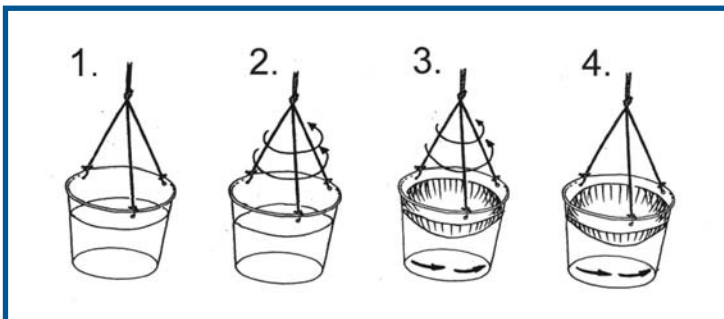

Fig. 3 Newton's "Rotating Bucket"

mattered. If the water was not spinning with respect to absolute space then its surface was level, but when it was spinning with respect to absolute space, the surface of the water was concave.

Newton then tried to make his argument for absolute space even stronger by introducing his "two globes in the void" TE (Fig. 4). He described this TE in the *Principia*:

... if two balls, at a given distance from each other with a cord connecting them, were revolving about a common center of gravity, the endeavor of the balls to recede from the axis of motion could be known from the tension of the cord, and thus the quantity of circular motion could be computed.

He argued that the tension in the cord would be registered even in a void where no other masses existed. Thus, Newton concluded in both cases that rotation had to be with respect to an absolute frame of reference.

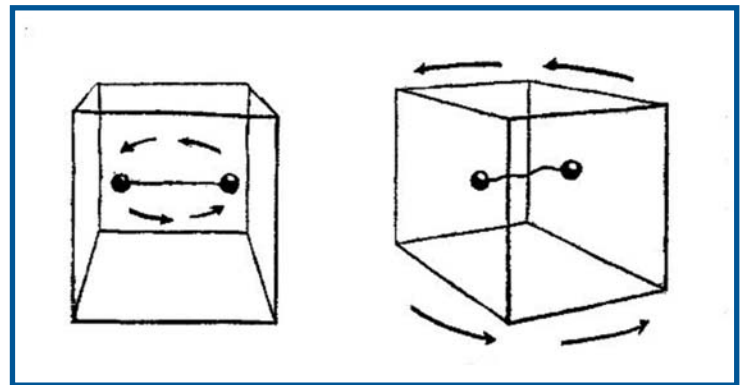

Fig. 4 Newton's two globes TE

Some twenty years after the publication of the *Principia*, the Irish Bishop and philosopher George Berkley argued that, since absolute space is unobservable, Newton's argument cannot be accepted. He further maintained that from Newton's TEs we can deduce that "centrifugal forces appear only when a body rotates *relative to the stars*" [6]. Referring to the second TE of Newton, he concluded his argument this way:

Let us imagine two globes and that besides them no other material exists, then the motion in the circle of these globes round their common centre cannot be imagined. But suppose that the heaven of fixed stars was suddenly created and we shall be in the position to imagine the motion of the globes by their relative position to the different parts of the heaven, (Quoted in [6].)

For almost two hundred years nothing significant was added to Berkley's arguments.

In the 1870s, the Austrian physicist and philosopher Ernst Mach reopened the debate by criticizing Newton's argument for absolute motion. He began by pointing out that mechanical experience can never teach us anything about absolute space. He insisted that we can only measure relative motions and therefore only these measurements are physically real.

Mach concluded that Newton's idea of absolute space therefore must be illusory.

Like Berkley, Mach claimed that Newton ignored the effects of the rest of the matter in the universe and in his own TE, he wondered "what if the sides of the bucket were 'several leagues' thick"?

Referring to this TE he wonders:

Nobody can say how the experiment would turn out, both quantitatively and qualitatively, if the bucket walls became increasingly thicker and more massive eventually several miles thick [7].

Mach also disagreed with Newton's two globes TE. He suggested that if the "experiments" were carried out in space without matter that the notion of rotation would be undetectable. Therefore, the rope holding the globes together would remain slack (Fig. 4). He concluded that in an otherwise empty universe, standing perfectly motionless and spinning uniformly are indistinguishable. His conclusion was that matter has inertia only because there is other matter in the universe. According to Mach then, inertial frames are those which are unaccelerated relative to the fixed stars. This vaguely expressed notion to replace Newton's idea of absolute space, was later dubbed "Mach's principle" by Einstein and it guided some of his thinking in developing the GTR.

There were two main objections leveled against what Einstein called Mach's principle [6]. First, it was argued that the laws of motion should be the same for all conceivable distributions of matter. Secondly, the principle was criticized because it makes no suggestions as to the nature of the coupling between the stars and local matter which is supposed to give the inertial effects. The second argument was considered the decisive one.

It is interesting to note that, according to the cosmologist Dennis Sciama (he was a student of Paul Dirac and a teacher of Steven Hawking), Mach's principle could have been used to make a prediction about the existence of a great number of galaxies in the universe. The very slow rotation of our Milky Way galaxy was not discovered until a decade after Mach died.

Sciama tantalizingly suggests that if Mach had known this, he could have used his principle "to predict the existence of an extragalactic universe, a universe which was not discovered until fifty years later" [6].

EINSTEIN'S THOUGHT EXPERIMENTS

Already as an adolescent, Einstein pondered the foundations of physics. In 1895, when he was 16 years old, he sent a paper to his uncle in Belgium about the ether and the magnetic field [2]. In his autobiographical notes of 1949, Einstein says:

When I was sixteen years old (in Aarau) the question came to me: If one runs after a light wave with a velocity equal to that of light, then one would encounter a time-independent wavefield. However, something like that does not seem to exist! (p. 130).

In other words, riding his light wave Einstein saw an electromagnetic field at rest, a paradox according to Maxwell's laws. He then remarked that "after ten years of reflection the principle of relativity resulted from this paradox upon which I had already hit at the age of sixteen" (p. 131).

According to Pais [2], Einstein felt certain of the truth of the Maxwell-Lorentz equations of electrodynamics and he reasoned that the invariance of the speed of light would ensure that these relations should hold in all inertial frames of reference.

However, this invariance was in conflict with the rule of addition of velocities according to the conventional addition of velocities based on Galilean relativity. Einstein puzzled over this problem for almost a year until he was convinced that *there was an inseparable connection between time and signal velocity*. Before he was comfortable in using the idea of different times for different inertial frames of reference, Einstein used a TE to give the idea of simultaneity an operational definition. To show that two events which are simultaneous in one frame of reference are not simultaneous in another he argued along the line found in the following TE, which is a "textbook" version of the TE that Einstein described in his paper. It is interesting to note that the railroad car version is actually a TE Einstein first described in a popular book he wrote in 1917. [Many versions of this TE can be found in text books. The following is a composite of several sources (Fig. 5)]:

As a train passes the physics student, two lightning bolts strike either end of the train leaving burn marks on the track and sending flashes of light into the train. The physics student sees the lightning bolts strike the two ends of the train simultaneously but she sees the two flashes of light meet at the center of the distance between the two burn marks, (as she must, since the speed of light in all directions is the same and independent of the source or observer.)

The passenger, however, sees things differently. He is standing in the middle of the train. After the lightning strikes he first sees a flash of light from the front of the train then a bit later a flash of light from the back of the train. As the speed of light is a constant in his frame as well he must conclude that the front of the train was struck by lightning before the back of the train.

The physics student and the passenger disagree as to whether the two events (the front and back lightning strikes) are simultaneous. But they are both correct. One might be tempted to say that the physics student must be correct since the passenger is moving and she is not. But the first postulate tells us that we can not tell the difference between moving frames. (Surely both the passenger and the physics student are "moving" as they are both on the Earth which is spinning on its axis and rotating around the Sun). So events which are simultaneous in one inertial frame, are not simultaneous as seen in another inertial frame.

This TE, of course, does not prove that simultaneity is relative. The conclusion Einstein reached is dependent on the acceptance of the speed of light as being constant relative to all frames of reference. But if the principle of the constancy of

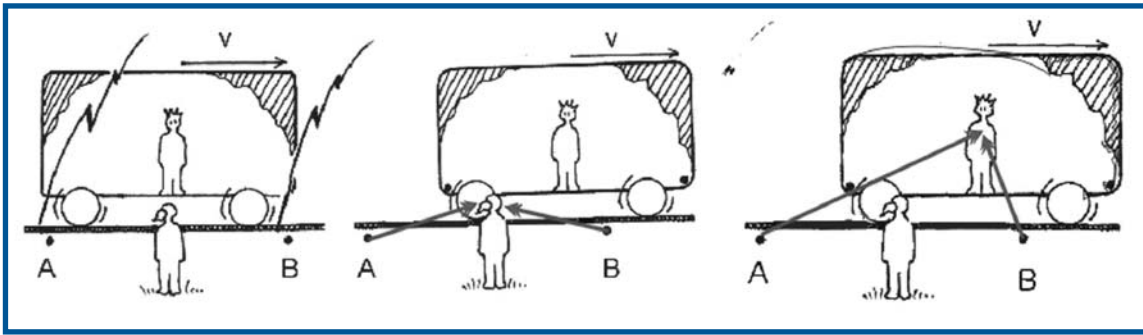

Fig. 5 Einstein's TE about the relativity of simultaneity - two events which are simultaneous in one frame of reference are not simultaneous in another.

observer in the stationary frame, is longer than the time interval $\Delta t'$, as measured by an observer in the moving frame.

We are now able to obtain a relationship between Δt and $\Delta t'$ by using Pythagoras' theorem applied to the right angled triangle.

$$(c \Delta t / 2)^2 = (v \Delta t / 2)^2 + d^2$$

light is accepted, then the conclusion that events that are simultaneous in one frame of reference may not be simultaneous in another, necessarily follows.

The following is a TE that we find in many college textbooks. It seems that this TE first appeared in the 1960's and was instantly recognized as an excellent pedagogical tool for teaching the ideas of the STR in first year university classes. In fact, when one first encounters this excellent TE it is tempting to think that it is just another TE devised by Einstein himself.

What follows is the time dilation effect TE, based on a standard physics textbook that we thought was especially well presented [8]. This TE is really an extension of the previous TE where we analyze the situation and derive a relationship between the measurement of time in the two frames of reference, the observer on the ground and the observer in the car.

Consider a vehicle moving to the right with a speed v , as shown in Fig.6. A mirror is fixed to the ceiling of the vehicle, and an observer O' at rest in this system holds a flashgun at a distance d from the mirror. At some instant the flashgun goes off and a pulse of light is released. Because the light pulse has a speed c , the time it takes to travel from the observer to the mirror and back again is found from the definition of velocity,

$$\Delta t' = \text{distance} / \text{velocity} = 2d / c$$

where $\Delta t'$ is the time interval as measured by O' , the observer who is at rest in the moving vehicle.

We will consider the same set of events as viewed by an observer in O , in the stationary frame. According to this observer, the mirror and flashgun are moving to the right with a speed of v . The sequence of events now are different, as seen in this frame. By the time the flashgun reaches the mirror, the mirror will have moved a distance of $v \Delta t / 2$, where Δt is the time it takes the light pulse to travel from O' to the mirror and back, as measured by the stationary observer. Comparing (a), (b), and (c) in Fig. 6. it is clear that the light must travel farther in the stationary frame than in the moving frame.

We can now use Einstein's second postulate, namely, that the speed of light must be c as measured by both observers. It follows then that the time interval Δt , as measured by the

Solving for Δt gives $\Delta t = 2 d / c (1 - v^2 / c^2)^{-1/2}$
 Since $\Delta t' = 2 d / c$
 It follows that $\Delta t = \Delta t' / (1 - v^2 / c^2)^{-1/2} = \gamma \Delta t'$
 $\gamma = 1 / (1 - v^2 / c^2)^{-1/2}$

This says that "the time interval, as measured by the observer in the stationary frame, is longer than that measured by the observer in the moving frame" by a factor of γ . The factor γ often appears in the so-called Lorentz transformations, and is sometimes called the 'Lorentz factor', after the Dutch physicist Hendrik Lorentz. These transformations were well known by 1905, but there is evidence to believe that Einstein at the time he wrote his famous paper was not acquainted with them [2].

The general conclusion drawn from this analysis is that all physical processes, including chemical and biological reactions, slow down relative to a stationary clock when they occur in a moving frame.

When Lorentz investigated the influence of the motion of the earth on electric and optical phenomena, he transformed the fundamental equations of the theory (valid in the frame of reference of the ether) to a frame of reference in motion with the earth. In order to get the result based on the requirement that these equations keep their form unaltered he had to postulate a time-transformation equation: $t' = t - v x / c^2$. Lorentz called t' the 'local time' but giving it only a formal significance, and considered it a "heuristic working hypothesis". Clearly, Einstein went beyond Lorentz.

The time dilation relationship immediately raised the question: Would the observer in the moving frame not come to the same conclusion about the "stationary" frame as far as the time dilation is concerned? The answer is yes, and this leads us to our next thought experiment.

THE TWIN PARADOX

We will conclude with the oldest and best known of all relativistic paradoxes, the so called twin paradox. This paradox was the testing ground for the counterintuitive results of time dilation that we have already discussed. Recently, Peter Pesic introduced his comprehensive article about the twin paradox this way [9]:

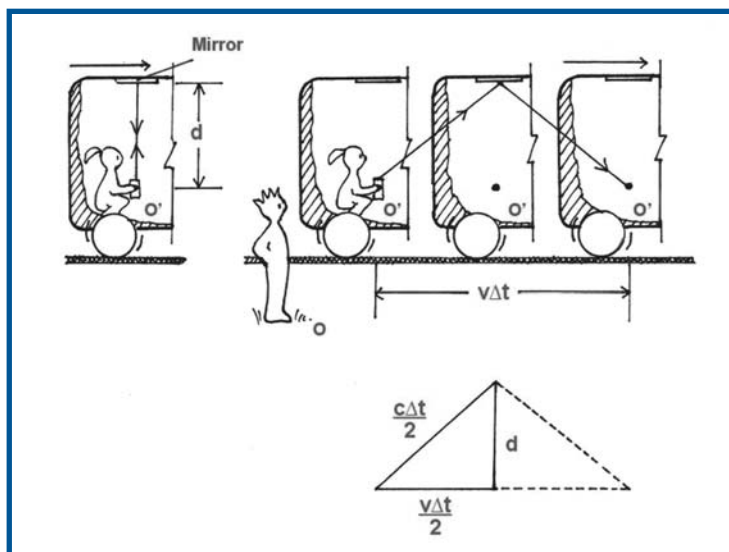

Fig. 6 A TE to show the time dilation effect - "moving clocks run slow".

However many times it has been analyzed, the twin paradox remains fascinating and puzzling to students. Wondering how and why identical twins could possibly age differently raises deep questions about the nature of time and leads to a deeper understanding of reality (p.585).

Physicists and students seldom read Einstein's original papers, and therefore their understanding of his ideas is based only on textbooks. Unfortunately, most textbooks generally devote less than a page to discussing the history of the paradox and resolve it quickly, not indicating any reservations about this conventional approach.

In his paper on relativity, Einstein notes what he calls a "peculiar consequence":

From this there ensues the following peculiar consequence. If at the points A and B of K there are stationary clocks which, viewed in the stationary system, are synchronous; and if the clock at A is moved with the velocity v along the line AB to B, then on its arrival at B the two clocks no longer synchronize, but the clock moved from A to B lags behind the other which has remained at B by $t = \frac{1}{2} t v^2 / c^2$ (up to magnitudes of fourth and higher order), t being the time occupied in the journey from A to B.

Thence we conclude that a balance-clock at the equator must go more slowly, by a very small amount, than a precisely similar clock situated at one of the poles under otherwise identical conditions.^[10]

Einstein called this result a *theorem* but it was later dubbed the *clock paradox* by the French physicist P. Langevin in 1911. Ultimately, it became the celebrated *twin paradox* (Fig. 7) that dealt with the so-called asymmetrical aging problem that was hotly debated in *Nature* in the years 1957-1959^[11], and is still debated today.

The *twin paradox* was raised in an attempt to use symmetry and time dilation to show that the STR

was inconsistent. For example, textbook writers, take it as axiomatic that "...there is no difference in principle between heartbeats and ticks of clocks".

Here is the paradox: Barb travels in a straight line at a relativistic speed v to some distant location. She then decelerates and returns. Her twin brother Bob stays at home on Earth. The situation is shown in the diagram, which is not to scale.

Bob observes that Barb's on-board clocks (including her biological one), which run at Barb's proper time, run slowly on both the outbound and return leg. He therefore concludes that she will be younger than he will be when she returns. On the outward leg Barb observes Bob's clock to run slowly, and she later also observes that it ticks slowly on the return run. So, will Barb conclude that Bob will have aged less? And if she does, who is correct? According to the proponents of the paradox, there is a symmetry between the two observers, so, using relativity, each will predict that the other is younger. This cannot be simultaneously true for both, so, if the argument is correct, relativity is wrong.

Most discussions of the twin paradox in textbooks point out that the motion of the twins is not symmetrical as there is an acceleration and deceleration at both ends of Barb's journey. Thus, Barb finds herself in a non-inertial reference frame four times during the trip while Bob has stayed in an inertial frame of reference all the time. According to STR, we simply refer to the clocks which are at all times in a single inertial system. Therefore, only Bob is allowed to apply the time dilation formula to Barb's entire voyage and the correct conclusion is that Barb is younger on her return. The asymmetric aging of the twins is then considered a consequence of the laws of nature. This is just the way nature works. Unfortunately, most textbooks imply that this is an obvious choice and do not offer further discussion.

However, the twin paradox almost immediately inspired significant debate. Shortly after Einstein's paper appeared, P. Langevin appealed to the acceleration phase of the journey as being significant in deciding who would be the younger twin at the end of the journey. Langevin's analysis was widely read and it challenged Einstein's own explanation based on the STR alone. Later, in 1913, Max von Laue returned to the acceleration matter, noting that it is possible to make the

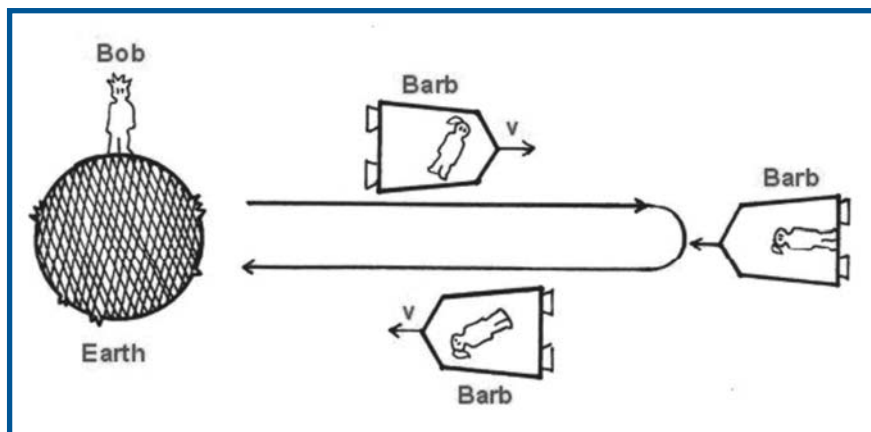

Fig. 7 The "Twin Paradox"

times of uniform motion arbitrarily greater than those of the acceleration. Additionally, Lorentz in his lectures at Leiden, also emphasized Einstein's simultaneity argument as sufficient^[9].

So it is interesting that Einstein in 1918 invoked his newly completed and confirmed GTR to explain the paradox^[9]. P. Pecic believes Einstein's emphasis on the GTR ensured that the argument that only the GTR is able to explain the paradox prevailed. It is interesting to note that, according to the physicist Richard Schlegel, Einstein said to him in 1952 that general relativity had nothing to do with the clock paradox^[11].

We now know that the STR, using the simultaneity argument, is able to resolve the twin paradox. However, there is still a confusion in the literature about how the STR and the GTR relate to the twin paradox.

Moreover, there are a number of physicists and philosophers who do not agree with the conventional resolution of this paradox, because they do not accept asymmetric aging^[12]. For example, textbook writers, take it as axiomatic that "...there is no difference in principle between heartbeats and ticks of clocks". These physicists do not accept this assumption without argument.

Finally, there is the argument that the time dilation is inconsistent with the length contraction of the STR. After a lecture of Einstein in 1911, a young law student asked Einstein: "According to your argument, Professor Einstein, at the moment of its meeting with the other clock at point A, the second clock will not be running in synchrony again. How can this be possible, since a rod of length L, shortened during the trip becomes its original length again?" The answer that Einstein gave to the student shows why we do not have a "length paradox" to go parallel with the twin paradox. We direct you to see P. Pecic^[9] for Einstein's illuminating response. Finally, it should be emphasized that the twin paradox is now considered a settled matter.

In spite of the fact that it is settled, the long history of the debate surrounding this fascinating paradox should be discussed with students. We recommend the following topics for discussion:

1. An argument for deciding that the twin who stays on an inertial system throughout the whole trip will be older.
2. The validity of the assumption that time dilation can be measured by clocks as well as by heart beats, i.e., asymmetrical aging applies to physical systems and biological systems equally.
3. The experimental evidence (such as the muon experiment) to confirm time dilation.

EINSTEIN'S THOUGHT EXPERIMENTS

It is intriguing that it was asymmetries that initially inspired Einstein to formulate many of his ideas around STR. In fact, Einstein's famous paper on relativity (actually titled: "On the electrodynamics of moving bodies")^[10] begins this way:

It is known that Maxwell's electrodynamics -- as usually understood at the present time -- when applied to moving

bodies, leads to asymmetries which do not appear to be inherent in the phenomena.

Einstein then describes the reciprocal electrodynamic action of a magnet and a conductor. He noted that the "observable phenomenon here depends only on the relative motion of the conductor and the magnet", but reminds us that

..., whereas the customary view draws a sharp distinction between the two cases in which either the one or the other of these bodies is in motion. For if the magnet is in motion and the conductor at rest, there arises in the neighborhood of the magnet an electric field with a certain definite energy, producing a current at the places where parts of the conductor are situated. But if the magnet is stationary and the conductor in motion, no electric field arises in the neighborhood of the magnet. In the conductor, however, we find an electromotive force, to which in itself there is no corresponding energy, but which gives rise--assuming equality of relative motion in the two cases discussed--to electric currents of the same path and intensity as those produced by the electric forces in the former case. (Fig. 8)

How was it possible to distinguish between the motion of a conductor towards a magnet on the one hand, and the motion of a magnet towards the conductor on the other? Maxwell's theory clearly distinguished between these two, as seen in this common-place phenomenon.

Most physicists are aware that relativity is involved in this commonplace demonstration (we can refer to it as the 'Faraday magnet and coil induction experiment'). This simple demonstration is often shown to students in junior high school. Unfortunately, when it is again discussed in senior high school, the demonstration is repeated with only a quick reference to Faraday's law. Teachers generally do not exploit the full significance of it as a simple demonstration of relativity. One reason may be that physics teachers in general are not aware that this simple experiment demonstrates a truly relativistic effect at very low velocities.

First of all, this demonstration shows that physical results depend only on the relative motion, and that electric and magnetic fields manifest themselves differently to moving observers. Secondly, a discussion of this demonstration can provide the motivation to study relativity the same way as it motivated Einstein to go beyond the conventional explanation.

The physicist John Norton on his website^[13] has recently remarked:

I am left wondering about all those people who moved magnets near wires and moved wires near magnet in physics classes before Einstein. Each time they conducted such experiments, and interpreted them as the result of two different processes, nature was telling them: "Hey, stupid, it's relative motion that matters only!"

This is a good example that illustrates the notion that we "see" with our ideas rather than our eyes. Refer to Block 1 for detail.

BLOCK 1

Case A: The coil is held stationary and the magnet is moved toward the coil. In this case the magnetic field does not affect the electrons in the coil, since their velocity is initially zero. This time, however, what produces the effect in the galvanometer is Faraday's law of induction, namely that a changing magnetic field produces a circular electric field: $\Delta \mathbf{B} / \Delta t = \mathbf{E}$ (actually $\mathbf{Grad} \mathbf{E} = 1/c \, d\mathbf{B}/dt$).

Case B: The magnet is held stationary and the coil is moved toward the magnet. Here the force that moves the electrons around the coil to produce the deflection in the galvanometer is the Lorentz force given by $\mathbf{F} = \mathbf{q} \mathbf{v} \mathbf{B} / c$, where v is the velocity of the coil toward the magnet.

It can now be stressed that

1. In case A there is only a magnetic field in the classroom, but in case B there is also an electric field in the classroom.
2. The galvanometer deflection is truly a relativistic effect, proportional to v/c (see Block 1)

In order to make the effect of motion on calculating electric and magnetic fields more accessible and plausible, we will present another thought experiment that we think clearly shows what Einstein said when he presented the magnet and coil experiment in his paper. The idea for the TE comes from Kirsh and Meida^[14], and is given in Block 2.

According to the STR, however, the observer in S' can use Maxwell's equations in his frame of reference. Granted, the forces acting between the electrons, according to the two observers, are not the same. However, due to the relativistic time dilation, the repulsive force observed in the laboratory frame, and the larger repulsive force in the moving frame will cause the same observed motion of the particle.

Solution

According to the S frame there are two forces acting on the electrons: an electric force and a magnetic force, F_e and F_m , where

BLOCK 2

Consider two electrons, which, at a given moment move close to each other so that their velocity vectors are equal in magnitude and direction, and are both perpendicular to the line connecting the electrons (See Fig. 9). According to an observer in the laboratory frame of reference (the S frame), there is an attractive magnetic force between the electrons, in addition to the repulsive electrostatic force between them. However, according to an observer in the S' frame, in which the two electrons are at rest, the only force acting between them is the electrostatic force! Kirsch and Meidav^[14] go on to say that before the STR was developed and routinely used, physicists explained this asymmetry by assuming that Maxwell's electrodynamics were *valid only in a specific inertial frame that was at rest relative to the ether*. If we now regarded S as the absolutely stationary frame, the observer in S' is not allowed to use Maxwell's equations in his frame and therefore *he cannot deduce there is no magnetic force between the particles*. Instead, he had to first do all the calculations in the S frame, and then translate the kinematic results to the S' coordinates by using the Galilean transformations.

$$F_e = q^2 / 4 \pi \epsilon_0 a^2 \quad \text{and} \quad F_m = -B v q$$

but $B = (\mu_0 / 4 \pi) \cdot q v / a^2$

Hence $F_m = -(\mu_0 / 4 \pi) \cdot q^2 v^2 / a^2$

Therefore $F = F_e + F_m = q^2 / 4 \pi \epsilon_0 a^2 - (\mu_0 / 4 \pi) \cdot q^2 v^2 / a^2$

Since $\epsilon_0 \mu_0 = 1 / c^2$, it follows that :
 $F = (q^2 / 4 \pi \epsilon_0 a^2) \{1 - v^2 / c^2\}$

Or we can say that $F = F_e \{1 - v^2 / c^2\}$

In other words the total force, as seen from the laboratory frame S is smaller than the force measured in the S' frame by a factor given by v^2 / c^2 . For small velocities this factor is negligible; even for a velocity of $0.1c$ it would only account for about 1% difference.

Since $\gamma = 1 / (1 - v^2 / c^2)^{1/2}$, which occurs in the Lorentz transformations and is called Lorentz factor, we can write $F = F_e / \gamma^2$

EINSTEIN'S TE TO SHOW THAT $E = MC^2$

It is generally agreed that the most dramatic consequence of the STR is expressed in the relation $E = mc^2$. In fact, this relation is regarded as the most famous equation of physics, not to mention as the most likely basis for solving the world's energy problems. Is it possible to derive this relation in a reasonably simple but convincing fashion for presentation to high school students?

This question was asked by Anthony Anderson in his very comprehensive short article "Einstein Out

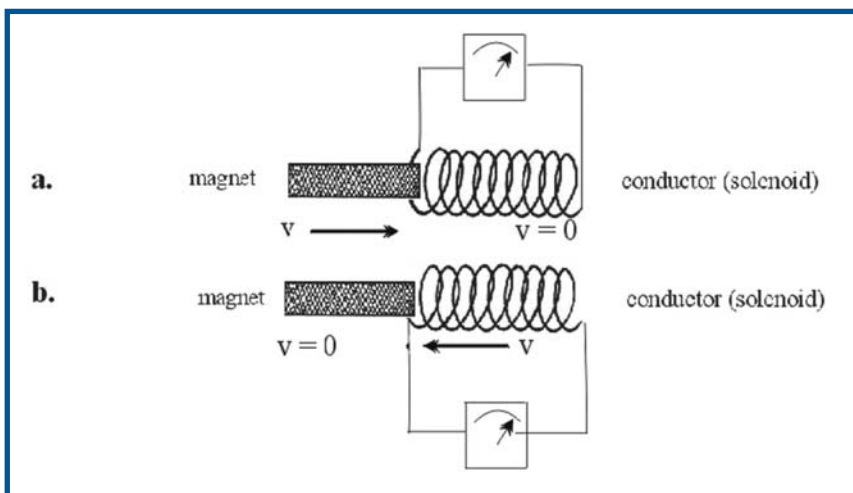

Fig. 8 A magnet and a solenoid *The Faraday induction demonstration.*

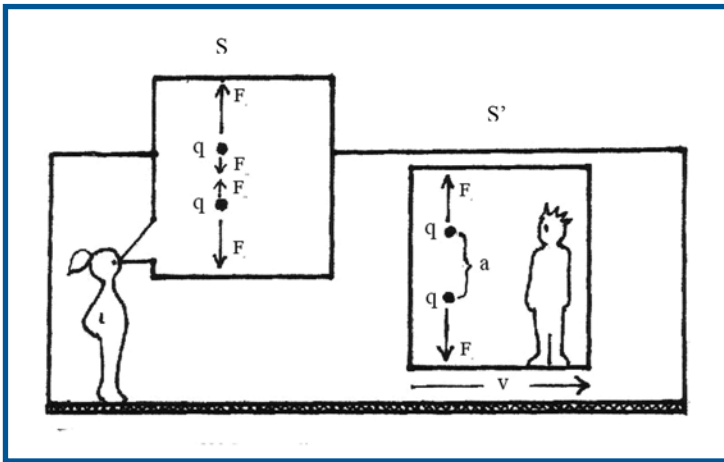

Fig. 9 Two electrons thought experiment.

Boxed" in *Physics 13 News*, June, 1977. He rightly argues that the usual text book approach is mathematically too sophisticated and presupposes knowledge of the Lorentz transformations. He then presents a revised version of the TE that Einstein himself described in his celebrated book, *Out of My Later Years*^[15]. Einstein introduces this TE by saying that it has not been published before. The description of the slightly revised version of Einstein's TE assumes two experimental results. First, the finiteness of the speed of light, *c*, and secondly, the relation that the energy *E* and momentum *p* carried by a burst of radiant energy is $\mathbf{p} = \mathbf{E}/c$. This has been predicted by Maxwell's E-M theory and later verified by experiments of radiation pressure by Nichols and Hull in 1901.

Note that for an isolated system, the center of mass must remain stationary. Or we could say that the acceleration of the center of mass of an isolated system, relative to an inertial reference frame, equals zero.

BLOCK 3

Consider a box, called Einstein's box, of mass *M* and length *L*. The box is stationary and is isolated from its surroundings (See Fig. 10). At time *t* = 0, a burst of radiant energy is emitted from the left end of the box. Since the radiation carries momentum \mathbf{E}/c , and since the total momentum must remain zero, the box recoils with a velocity ,

$$\mathbf{v} = -\mathbf{E}/(M\mathbf{c}).$$

After time *t* - *t*₁, the radiation hits the right end of the box, is totally absorbed, and brings the box to rest. again. The box has travelled a distance of Δx given by

$$\Delta x = \mathbf{v}t_1 \quad \text{with } t_1 = L/c \quad (\text{assuming that } \mathbf{v} \ll c)$$

Hence

$$\Delta x = -EL/Mc^2$$

We therefore postulate that the radiation has carried the equivalent of a mass *m*, from one end of the box to the other. It follows then that

$$mL + M \Delta x = 0$$

$$\therefore m = -M \Delta x/L = -M/L (-EL/Mc^2) = E/c^2$$

or

$$E = mc^2$$

That is, any change ΔE in the energy of a body produces a corresponding change in Δm in its inertial mass. A heated filament, for example, has more mass than the same filament when it is cold. In an exothermic chemical reaction, there is always a corresponding mass change. However, this mass change is so small that it cannot be measured. It has been calculated that the energy used per day for domestic purposes in a city of a million people has a mass equivalence of only about 1 g .

Einstein himself did not know how this result could be tested experimentally at the time of the publication of his paper. In the closing remarks of his short addendum to the relativity paper in 1906, entitled: *Does the Inertia of a Body Depend on the Its Energy Content?* in which he offers the formal derivation of his famous equation, Einstein closes with this note: "...radium salts may perhaps be used to test this prediction". But he was not sure.

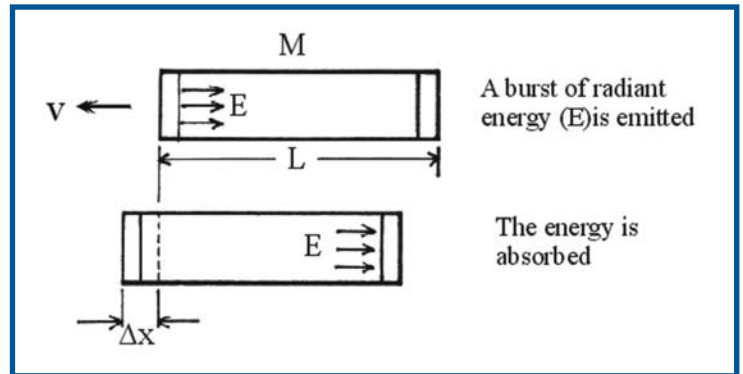

Fig. 10: Einstein's TE to show that $E = mc^2$

EINSTEIN'S ELEVATOR TE

In conclusion, we must make a brief connection with the GTR. Shortly after the publication of his STR paper in 1905, Einstein wondered how relativity theory could embrace all frames of reference, including accelerating frames of reference. Einstein realized that his STR was not compatible with Newton's law of gravitation. For example, Newton's law of gravity, expressed as $F = Gm_1m_2/r^2$, did not contain the variable for time. One of Newton's assumptions was the idea of action-at-a-distance that many of his contemporaries and later Mach and others found unacceptable. According to Newton, if the gravitational effect of the sun suddenly disappeared, the earth, and all the other planets would move tangentially to their orbit instantly. According to Einstein's STR, on the other hand, the gravitational effect travels with the speed of light and therefore would take about eight minutes for it to reach the earth. In that time the earth would move in its orbit for another 8 minutes as if the sun's gravity existed .

We should add at this point that the most famous part of the STR is that inertial mass and energy are equivalent. However, it is generally accepted that the mass-energy equivalence is

not a logical consequence of the STR. Einstein noted when the mass-energy equivalence is combined with the gravitational equivalence principle, it becomes technically incompatible with the STR. He therefore tried to generalize the STR to accommodate gravitation consistently. Of course, as already mentioned, the mass-energy equivalence was already suspected by Poincaré, as well as Lorentz.

In November of 1907, while working on a paper on the SRT, Einstein tried to modify Newtonian theory of gravitation "in such a way that its laws would fit in the special relativity theory" [2]. Later, in his Kyoto lecture of 1921 Einstein recalls that:

I was sitting in the patent office at Bern when all of a sudden a thought occurred to me: 'If a person falls freely he will not feel his own weight'. I was startled. This simple thought made a deep impression on me. It impelled me toward a theory of gravitation.

In an earlier version of this story he continues as follows:

Then there occurred to me the 'happiest thought of my life' in the following form. The gravitational field has only a relative existence in a way similar to the electric field generated by electromagnetic induction. Because for an observer falling freely from the roof of a house there exists - at least in his immediate surroundings - no gravitational field. Indeed, if the observer drops some bodies then they remain relative to him in a state of rest or in uniform motion. The observer therefore has the right to interpret his state as 'at rest'. Because of this idea, the uncommonly peculiar experimental law that in a gravitational field all bodies fall with the same acceleration, attained at once a deep meaning [2] (page 178).

Einstein then concludes by saying that the experimentally known fact that all masses fall with the same acceleration in a gravitational field is a powerful argument for extending the relativity postulate to coordinate systems which, relative to each other, are in non-uniform motion.

As we have mentioned earlier, at the age of sixteen in 1896, his TE of riding on the beam of light marked the beginning of his quest that ultimately took him to completing his SRT in 1905; and in 1907, his TE of falling in a gravitational field compelled him to work toward a new theory of gravity, completed in 1916, now known as the general relativity theory (GRT),

We will conclude with Einstein's elevator TE that first appeared in *The Evolution of Physics*, a book that was written with Leopold Infeld for the general public in 1938 [16]. The elevator TE is introduced this way:

The law of inertia marks the first advance in physics, its real beginning. It was gained by the contemplation of an idealized experiment, a body moving forever with no friction nor any other external forces acting. Here again, idealized experiments will be discussed. Although these may sound very fantastic, they will, nevertheless, help us to understand as much about relativity as possible by our simple method. We had previously the idealized experiments with a uniformly moving room. Here, for a change, we shall have a falling elevator. (p. 214).

We, too, have come full circle with our TE presentation. We began with Galileo and his ship that represented an inertial frame of reference and now we are looking at the question of how accelerating frames of reference and gravity are related. To illustrate that principle, Einstein proposed a thought experiment involving elevators, with no windows. In his original version, however, he placed the non-accelerating elevator on the Earth, the accelerating elevator just above it. We will change this TE a little (with apologies to Einstein) and place one elevator in deep space (no gravity) and the other on the Earth at rest (Fig. 11).

One elevator is in deep space and is moving with an acceleration of 1 g. An identical elevator is placed on the surface of the earth, but is at rest. Einstein claimed that there is no experiment that can be done in the elevators to decide in which elevator the physicist is doing the experiments.

The following can be discussed in class: Imagine physics students doing identical experiments in both elevators and are communicating with each other, being able to do so instantly. They perform experiments like: testing free fall, finding the period of a pendulum, the period of a spring; they even find the bending of light using a laser. According to Einstein's equivalence principle, their results should be identical. Is there really no experiment that could be done to tell the physics student where she is?

If mechanical experiments cannot distinguish between the two elevators, an optical experiment might. Using a laser we would find (assuming that the slight change were measurable) that the trajectory of the laser would follow parabolic path in both elevators, in analogy with the parabolic path of a ball thrown in a horizontal direction in the gravitational field of the earth. So light, according to Einstein, should bend in a gravitational field in a predictable way. Finally, light always follows a shortest-time path between two points, so the shortest distance between two points will no longer be a straight line but a *geodesic* that describes the path of light [17].

These TEs then convinced Einstein that the correct way to formulate a theory of gravity was to construct a theory of motion that was consistent with the STR which gave, in the non-relativistic limit, Newton's inverse square law of gravity. Finally, students should compare Galilean relativity with Einsteinian by going back to our first TE.

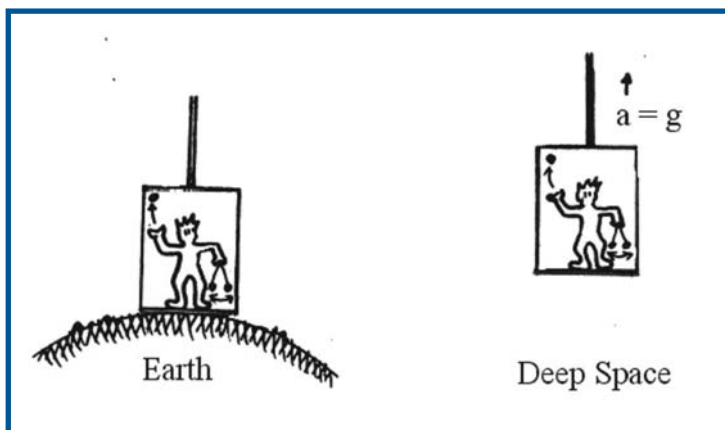

Fig. 11 Einstein's elevator TE

Einstein based his GTR on two postulates and Mach's principle: 1. The principle of relativity (the laws of nature must be given in terms of continuous field variables) and 2. The equivalence principle. The physics of the STR is assumed to be correct.

Non-uniform motion is, of course, the only kind of motion that can actually be experienced by matter, when matter interacts with other matter. This is so because matter interacts due to a force (by definition), causing mutual transfer of energy and momentum. But force is the cause of non-uniform motion. Therefore, Einstein reasoned, STR must be a limiting case of the theory of relativity.

As described in the elevator TE, Einstein concluded that the effects of gravitation and those due to acceleration cannot be distinguished. Newtonian mechanics distinguishes between the motion of a body that is inertial (subject to no forces) and the motion of a body subject to the action of gravity. The former is rectilinear and uniform in an inertial system; the latter occurs in curvilinear paths and is non uniform. The principle of equivalence, however, does not allow this distinction. Einstein's mandate now was to state the law of inertial motion in the generalized sense. The solution of this problem banishes both the notion of absolute space and force and gives us a theory of gravitation. ^[2,17].

In Newton's theory the symbol F in $F = ma$ refers to the cause of the acceleration of the body. Force then is an external agent that acts on matter with an inertial mass m , causing it to accelerate at the rate a . In the GTR, however, there is no external force. Indeed, Einstein was able to derive Newton's equation $F = ma$ from purely geometric considerations. He saw the possibility that all "external" forces may be only apparent—that the 'effect' of other matter may be representable by a generalization of the geometry of space-time that describe the motions.

EXPERIMENTAL CONFIRMATION OF THE PREDICTIONS MADE BY EINSTEIN

A good theory in science, like Newton's theory of gravity and the kinetic molecular theory of gases, must be able to make significant predictions that can be experimentally tested and confirmed. In addition, a good theory must also be able to explain more and better than competing theories those phenomena that fall within its domain.

The STR made several predictions that could be experimentally tested or observed. These were:

1. Time dilation
 $\Delta t = \Delta t' / (1 - v^2/c^2)^{1/2}$, or $\Delta t = \gamma \Delta t'$
2. Length contraction
 $L = L_0 (1 - v^2/c^2)^{1/2}$, or $L = L_0/\gamma$
3. Relative velocity
 $V_{Rel} = (V_1 + V_2) / (1 + V_1 V_2/c^2)$
4. Apparent mass increase, and
 $M = M_0 / (1 - v^2/c^2)^{1/2}$, or $M = M_0 \gamma$
5. The conversion of mass into energy according to the formula
 $E = mc^2$

The GTR also made predictions that could be tested. In his 1915 paper on the GTR Einstein suggested three experimental tests that he thought could be used to confirm his theory.

These were:

1. The redshift of spectral lines that emerge from regions of high gravity like that of the sun,
2. The deflection of light as it passes through strong gravitational field, like that of the sun, and
3. The precession of planetary orbits, an effect already detected in the 19th century, most convincingly for the case of Mercury.

We will make only a few comments here and refer the reader to two excellent sources for a detailed discussion of these. For the STR and its experimental consequences we recommend Pais ^[2] and for the GTR we found Rowlands ^[18] to be an outstanding paper.

First of all, as far as the STR is concerned, we should keep in mind that the four quantities, time dilation, length contraction, relative velocity and apparent mass increase, are intrinsically connected; therefore one effect necessarily implies the other. In addition, students should be told that the experimental tests to confirm these took a long time and the findings were often controversial. For example, it was not until about 1910 that experiments with cathode rays clearly showed that the Einsteinian interpretation was superior to any of the proposed classical hypotheses to explain the observed mass increase of the electrons moving with a high velocity. Time dilation (and therefore also length contraction) was not confirmed by an experiment until 1941, detecting the arrival of muons produced in the atmosphere by cosmic rays. The famous equation $E = mc^2$ was suggested in the Compton Effect in 1923, and later confirmed by the neutron-induced fission reaction first reported by Otto Hahn and Fritz Strassmann in 1938. About the same time Hans Bethe presented a model for the thermonuclear reactions in the sun that showed that the age of the sun must be about 4-5 billion years.

Secondly, as far as the GTR is concerned, all three predictions made by Einstein in 1915 have been confirmed. It is interesting to note that the gravitational redshift is the simplest of the effects to explain but the most difficult to test. In fact, it was not confirmed until 1960, five years after Einstein's death.

The gravitational deflection of light from a star, as it passed close to the sun, was measured in 1919 by Eddington and his group during a solar eclipse, confirming Einstein's prediction. This is the highly publicized observation that launched Einstein to instant world fame.

The last effect, the precession of Mercury's perihelion, was the first to be confirmed by GTR. Einstein knew that in 1859 the French astronomer Leverrier, later corroborated by the British astronomer Simon Newcombe, that, of the 574 arc seconds per century, 531 of which could be accounted for by perturbations due to other planets. But the remaining 43 arcseconds resisted all analysis ^[14]. Einstein found that his GTR could account for these 43 arcseconds exactly. This incredible match between theory and observation delighted Einstein and he wrote: 'I was beside myself with ecstasy for days' ^[2,18].

Two things should be mentioned that are generally not known. First, Einstein predicted the gravitational redshift effect as early as 1907 and derived the equation based on more rigorous arguments in 1911. Clearly, one does not need the GTR to derive this equation. Secondly, it is interesting to note that all three effects mentioned in connection with the GTR can be derived, using only Newtonian theory and the STR^[18]. This claim can lead to a good discussion in a senior university course.

Finally, students should realize that the STR still has absolutes. The absolute space of Newton has been replaced by a new absolute, namely 'space-time', or 'space time interval'. In Newtonian space the distance between two points is expressed by writing $\Delta s^2 = x^2 + y^2 + z^2$ (Pythagoras' theorem) and the distance Δs is the same, measured from any inertial frame of reference. However, in STR this distance will change for different inertial frames of reference. What remains constant, however, is $\Delta S^2 = x^2 + y^2 + z^2 - c^2 t^2$, as measured from any inertial frame of reference. This feature of STR was first pointed out by Hermann Minkowski in 1908, the mathematics professor of Einstein at the Zurich ETH.

Although velocities, distances, and time intervals are relative, the STR still sits on a postulated absolute space-time. Observers moving at constant velocities relative to each other, would not agree on the velocity of a bucket moving through space, the distance it covered, nor would they agree about the time that had elapsed in the bucket experiment. But they would all agree on the space-time interval and whether or not the bucket was accelerating.

CONCLUDING REMARKS

The TEs presented here can be injected into the senior high school or first year college/ university physics program as the instructor sees fit, with the following in mind: the story aspect, or the historical background of the TE, must be considered a necessary but not sufficient condition for a successful presentation of the TE. The TE must also be discussed in such a way that the argument and the quantitative aspect of the TE is comprehensible to the student.

Finally, we should be reminded that physics teachers are still confronted by the prevailing myth that Einstein's relativity theories are understood only by physicists. Countering this claim, Abraham Pais, referring to Einstein's great paper on relativity, challenged physics teachers: "It also seems to me that this kinematics, including the addition of velocity theorem, could and should be taught in high schools as the simplest example of the ways in which modern physics goes beyond intuition"^[2] (p. 141).

At the same time, however, the remark made by a noted expert in the field, A.P. French, rings true for all of us who have wrestled with the concepts and assumptions of the STR over many years:

No matter how long one has lived with the results of special relativity, there is something very counterintuitive about it^[19] (p. 89).

It seems then that early and long exposure to these concepts and ideas is necessary in order to become comfortable with them. As Kuhn pointed out in his *Structure of Scientific Revolutions*, those who come to revolutionary new ideas (such as the ones in the STR) late in life can sometimes be *converted*, while those who grow up with them are *persuaded* at an early age and become comfortable with these ideas and concepts. Introducing students early to the ideas of Einstein in what Jerome Bruner called "an intellectually honest way", will ensure a much longer gestation time to prepare them for a less jolting encounter of these ideas later.

ACKNOWLEDGEMENTS

I wish to thank my wife, Ann, for designing the attractive figures, and the reviewer for the thorough reading of the manuscript and the many helpful suggestions for improving the paper.

REFERENCES

1. C. Swartz, "On the teaching of Newtonian Physics to Aristotelian minds in the days of quantum operators". *The Physics Teacher*, **Vol. 19** No 1., p. 10 (1981).
2. A. Pais, *The Science and the Life of Albert Einstein*, Oxford University Press (1982).
3. A. Stinner, "The Story of Force: From Aristotle to Einstein", *Physics Education*, **2**, 77-86 (1994).
4. J. Brown, *Smoke and Mirrors: How science reflects reality*, Routledge, New York (1994).
5. I. Newton, *The Principia: Mathematical Principles of Natural Philosophy*, Eds. and trans. I.B. Cohen and Anne Whitman. Berkeley, University of California Press, ([1726] 1999).
6. D. Sciama, *The Unity of the Universe*, Anchor Books, Double Day, New York (1961).
7. E. Mach, *The Science of Mechanics, sixth edition*, Trans. Thomas J. McCormack, LaSalle, Illinois, Open Court Publishing (1908).
8. R. Serway, and J. Faughn, *College Physics, 6th Edition* (2003).
9. P. Pesic, "Einstein and the twin paradox", *Physics Education*, **24**, 585-590 (2003).
10. A. Einstein, "On the electrodynamics of moving bodies.", *Annalen der Physik*, (1905).
11. R. Schlegel, *Time and the Physical World*, Michigan State University Press (1967).
12. M. Sachs, *Ideas of the Theory of Relativity*, Halsted Press (1974).
13. J. Norton website: [<http://www.pitt.edu/~jdnorton/?dnorton/html>.] Online.
14. Y. Kirsh and M. Meidav, "The Michelson-Morley experiment and the teaching of special relativity", *Physics Education*, **22**, 270-273 (1987).
15. A. Einstein, *Out of my later years*, The Citadel Press, New Jersey ([1947], 1967).
16. A. Einstein, and L. Infeld, *The Evolution of Physics*, Simon and Shuster (1966).
17. M. Born, *Einstein's Theory of Relativity*, Dover Publications, INC, New York (1962).
18. P. Rowlands, "A simple approach to the consequences of general relativity", *Physics Education*, **32**, No 1, 49-55. (1997).
19. A.P. French, *Special Relativity*, W.W. Norton & Co. New York (1968).